

THROTTLE

0–5k Ω Input

The standard controller throttle input is 0–5k Ω . Curtis PMC potboxes (PB-5, -6, -9, -10) are designed to match this input. Some of these potboxes have a built-in microswitch, eliminating the need to install a separate pedal-actuated microswitch. Curtis PMC also offers a self-contained footpedal unit (FP-2) that eliminates the need for fabricating and installing a pedal-potbox linkage. Mounting dimensions for the potboxes and for the footpedal unit are shown in Figures 4 and 5.

Any potbox that provides a nominal 0–5k Ω output (controller output begins at \approx 300 ohms, full output is \approx 4400 ohms) will work with the standard throttle input. For other types, contact your Curtis office.

If a Curtis PMC potbox is used, it must be mounted so as to allow connection between the potbox lever arm and the vehicle accelerator linkage. The lever arm provides a series of holes so that the accelerator pedal “throw” can be converted into the correct amount of potentiometer rotation. Use of a second return spring on the pedal, in addition to the potbox return spring, is required to prevent an uncontrollable full-on throttle input (which could happen if there was a single spring, and it broke). If the self-contained potbox spring is insufficient to return the pedal by itself, two additional pedal return springs must be used.

It is also required that the accelerator pedal hit a mechanical stop at its full-on position just before (\approx 1 mm [1/32"–1/16"]) the potbox lever hits its own full-on stop. This mechanical stop will prevent the potbox lever arm from bending if undue force is put on the pedal. Protection of the potbox from water and dirt will help avoid problems of corrosion and electrical leakage.

After the potbox has been mounted, operation of the pot can be tested by measuring the resistance between the two wires with an ohmmeter. With the pedal not applied, the resistance should be less than 50 ohms. As the pedal is applied, the resistance should rise smoothly until it reaches a value between 4500 and 5500 ohms. Values below 4500 ohms may cause a reduction in efficiency and top speed. Values above 7000 ohms indicate a defective potbox, and will cause controller shutdown.

5k Ω –0 Input

The 1204X/1205X/1209/1221 controllers are also available with 5k Ω –0 throttle inputs. Using this throttle type, controller output begins at \approx 4400 ohms with full output at less than 300 ohms.

Fig. 4 Mounting dimensions, Curtis PMC potboxes PB-5, -6, -9, and -10.

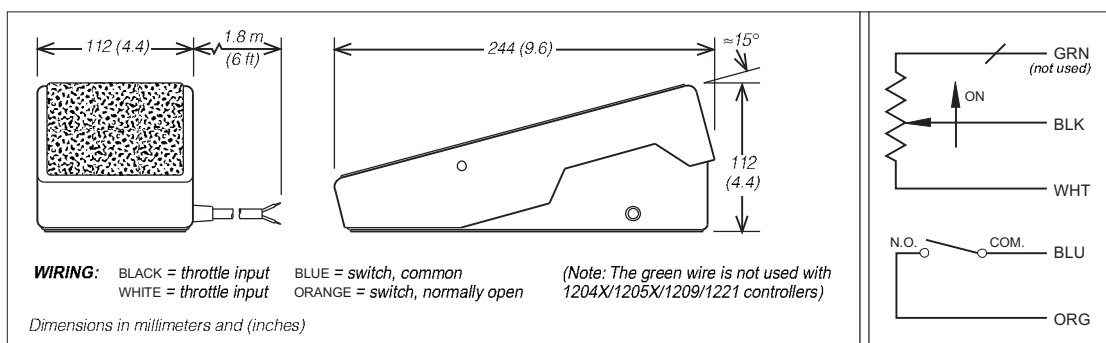
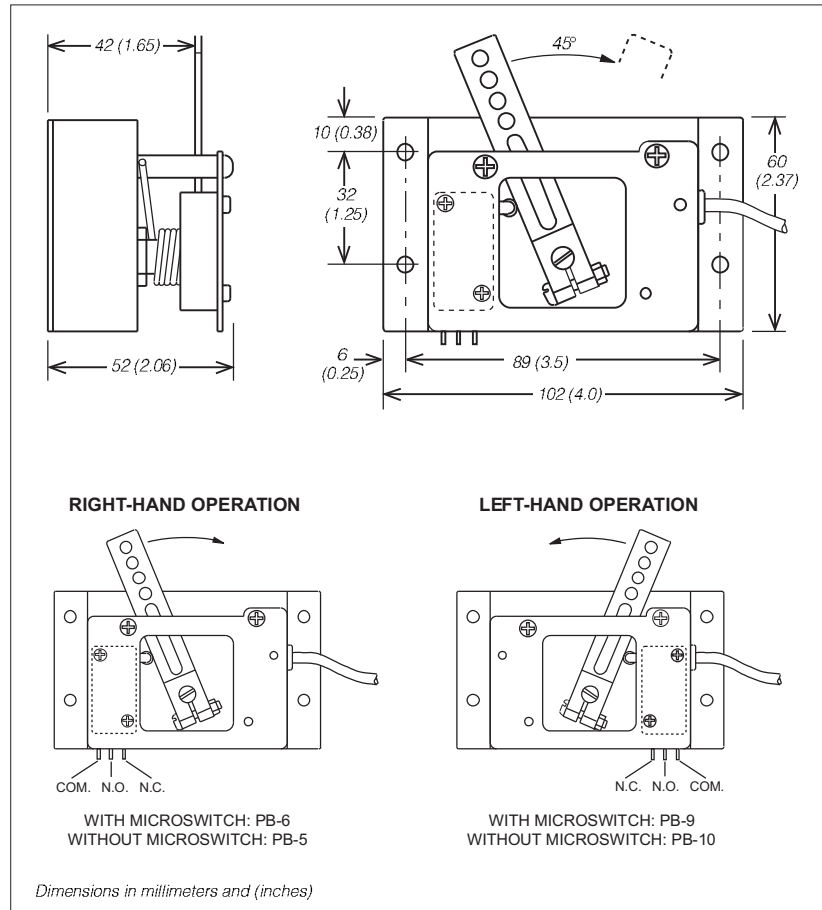

Fig. 5 Curtis PMC footpedal FP-2.

0–5V Input

A 0–5V throttle input option is also available for the 1204X/1205X/1209/1221 controllers. The negative side of the 5V source should be referenced to B- and must be capable of driving an input impedance of 5k Ω .

Curtis offers two bi-directional, wigwag electronic throttle assemblies designed for use with the 0–5V input: the ET series and the CH series.

The ET-XXX throttle assembly provides a 0–5V output and forward/reverse relay coil drivers. Dimensions for the ET-series electronic throttles are shown in Figure 6. The CH-XXX is a complete control head assembly, consisting of an ET-XXX throttle integrated into a molded steel and plastic assembly designed for mounting directly to a tiller stem. For more information about ET and CH products, contact your nearest Curtis office.

Fig. 6 Mounting dimensions, Curtis electronic throttle (ET series).

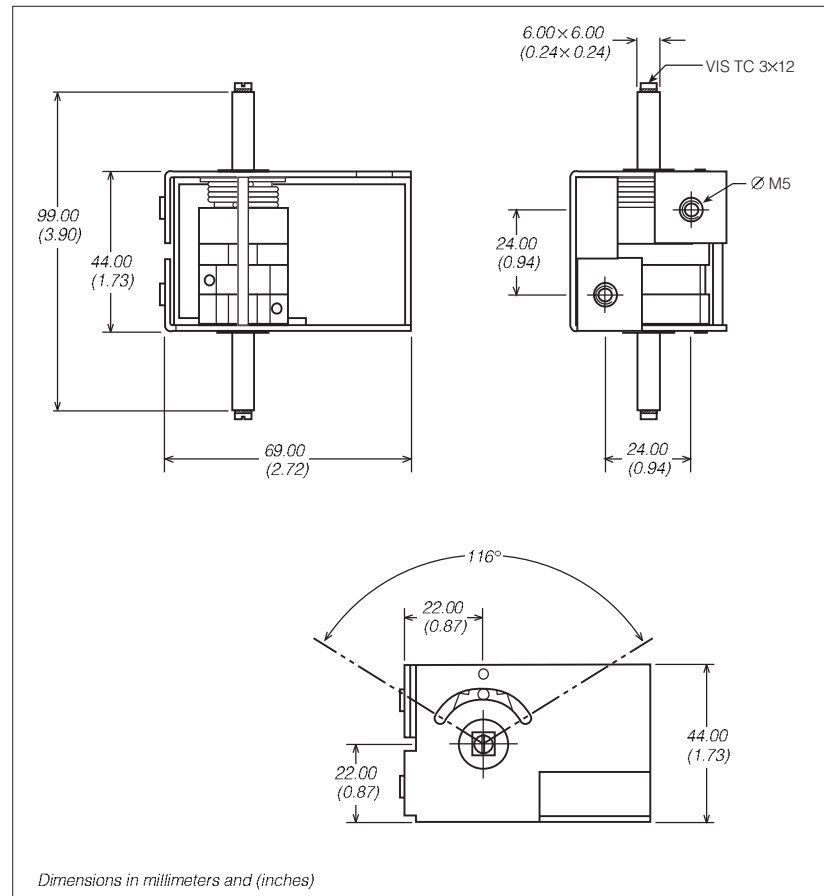

OTHER HARDWARE

The recommended hardware for a typical 1204X/1205X/1209/1221 controller installation is shown in Figure 7.

Contactors should be mounted in a clean, dry location. If such a location is unavailable, a cover should be used to deflect dirt and water splash.

The precharge resistor connected to the main contactor, and the coil suppression diodes connected to the main contactor and to the forward/reverse contactors, are somewhat delicate components. Care should be taken to prevent damage to them during installation.

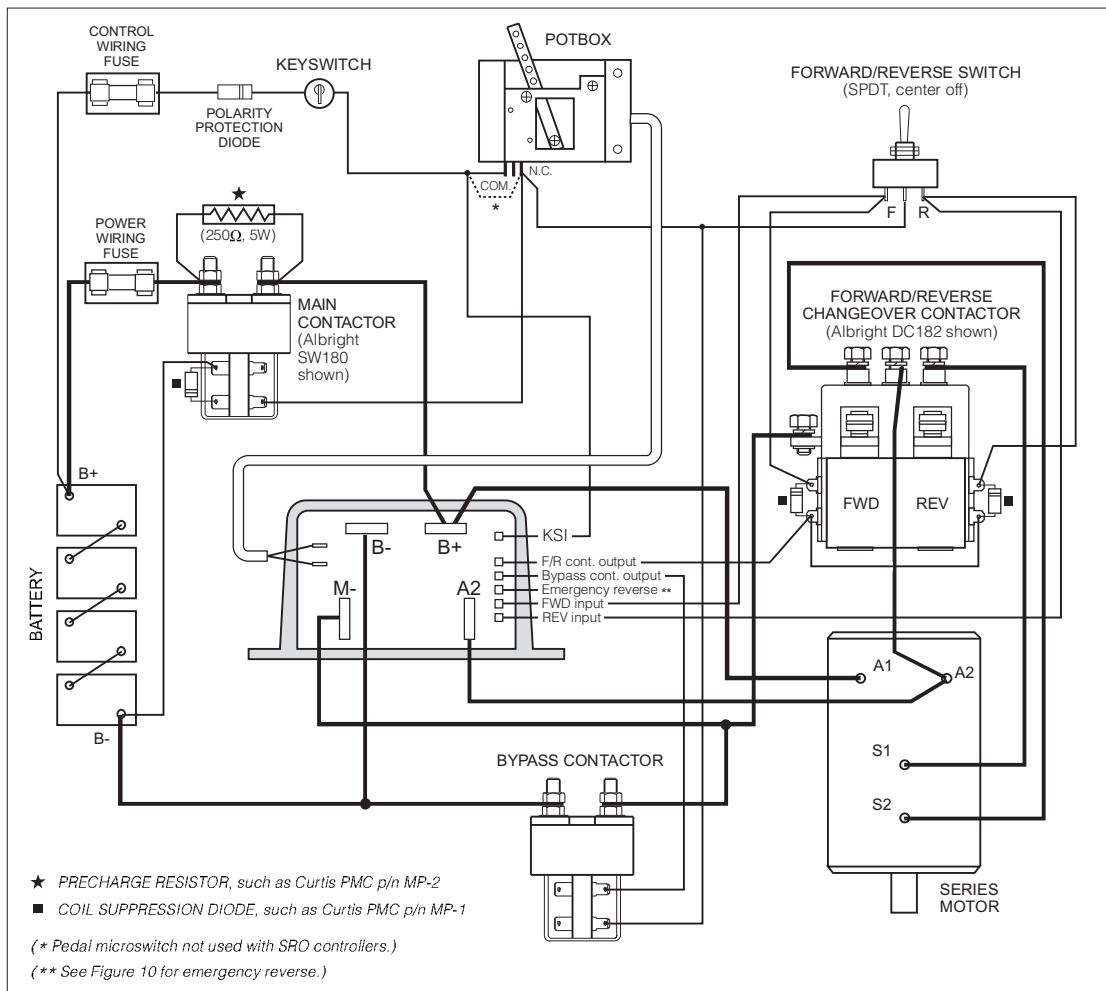

Fig. 7 Typical installation, Curtis PMC 1204X/1205X/1209/1221 controllers.